

## ◆ UNSFP10-2733SL10X

10Gbps SFP+ Tx1270nm/Rx1330nm BiDi 10Km Transceiver

### Product Feature

- Up to 11.3G/s data links
- DFB laser transmitter and PIN photo-detector
- Up to 10km on 9/125μm SMF
- Hot-pluggable SFP footprint
- Single LC/UPC type pluggable optical interface
- Low power dissipation
- Metal enclosure, for lower EMI
- RoHS compliant and lead-free
- Single +3.3V power supply
- Support Digital Diagnostic Monitoring interface
- Compliant with SFF-8472
- Case operating temperature

Commercial: 0°C to +70°C

Industrial: -40°C to +85°C





Shenzhen UnitekFiber Solution Limited

## Applications

- 10GBASE-BX&10GBASE-BX/LW
- 10GSONET/SDH,OTU2/2e
- Other Optical Links



## Product Description

KSFP10-2733SL20X Small Form Factor Pluggable (SFP) transceivers are compatible with the Small Form Factor Pluggable Multi-Sourcing Agreement (MSA). The transceiver consists of five sections: the LD driver, the limiting amplifier, the digital diagnostic monitor, the DFB laser and the PIN photo-detector .The module data link up to 10KM in 9/125um single mode fiber.

The optical output can be disabled by a TTL logic high-level input of Tx Disable, and the system also can disable the module via I2C. Tx Fault is provided to indicate that degradation of the laser. Loss of signal (LOS) output is provided to indicate the loss of an input optical signal of receiver or the link status with partner. The system can also get the LOS (or Link)/Disable/Fault information via I2C register access.

## Product Selection

Part Number	Operating Case temperature	DDMI
KSFP10-2733SL20C	Commercial(0~70°C)	Yes
KSFP10-2733SL20I	Industrial(-40~85°C)	Yes

## Pin Descriptions

Pin	Symbol	Name/Description	NOTE
1	VEET	Transmitter Ground (Common with Receiver Ground)	1
2	TFAULT	Transmitter Fault.	
3	TDIS	Transmitter Disable. Laser output disabled on high or open.	2
4	SDA	2 wire ID interface,SDA	3
5	SCL	2 wire ID interface,SCL	3
6	MOD_DEF(0)	Module Definition 0. Grounded within the module.	3
7	RS0	No connection required	4
8	LOS	Loss of Signal indication. Logic 0 indicates normal operation.	5
9	RS1	Receiver Ground (Common with Transmitter Ground)	1
10	VEER	Receiver Ground (Common with Transmitter Ground)	1
11	VEER	Receiver Ground (Common with Transmitter Ground)	1
12	RD-	Receiver Inverted DATA out. AC Coupled	
13	RD+	Receiver Non-inverted DATA out. AC Coupled	
14	VEER	Receiver Ground (Common with Transmitter Ground)	1
15	VCCR	Receiver Power Supply	
16	VCCT	Transmitter Power Supply	
17	VEET	Transmitter Ground (Common with Receiver Ground)	1
18	TD+	Transmitter Non-Inverted DATA in. AC Coupled.	
19	TD-	Transmitter Inverted DATA in. AC Coupled.	
20	VEET	Transmitter Ground (Common with Receiver Ground)	1

Notes:

1. Circuit ground is internally isolated from chassis ground.
2. Laser output disabled on  $T_{DIS} > 2.0V$  or open, enabled on  $T_{DIS} < 0.8V$ .
3. Should be pulled up with 4.7k - 10kohms on host board to a voltage between 2.0V and 3.6V. MOD\_DEF (0) pulls line low to indicate module is plugged in.
4. This is an optional input used to control the receiver bandwidth for compatibility with multiple data rates (most likely Fiber Channel 1x and 2x Rates). If implemented, the input will be internally pulled down with  $> 30k\Omega$  resistor. The input states are:
  - Low (0 – 0.8V): Reduced Bandwidth
  - ( $>0.8, < 2.0V$ ): Undefined
  - High (2.0 – 3.465V): Full Bandwidth
  - Open: Reduced Bandwidth
5. LOS is open collector output should be pulled up with 4.7k - 10kohms on host board to a voltage between 2.0V and 3.6V. Logic 0 indicates normal operation; logic 1 indicates loss of signal.

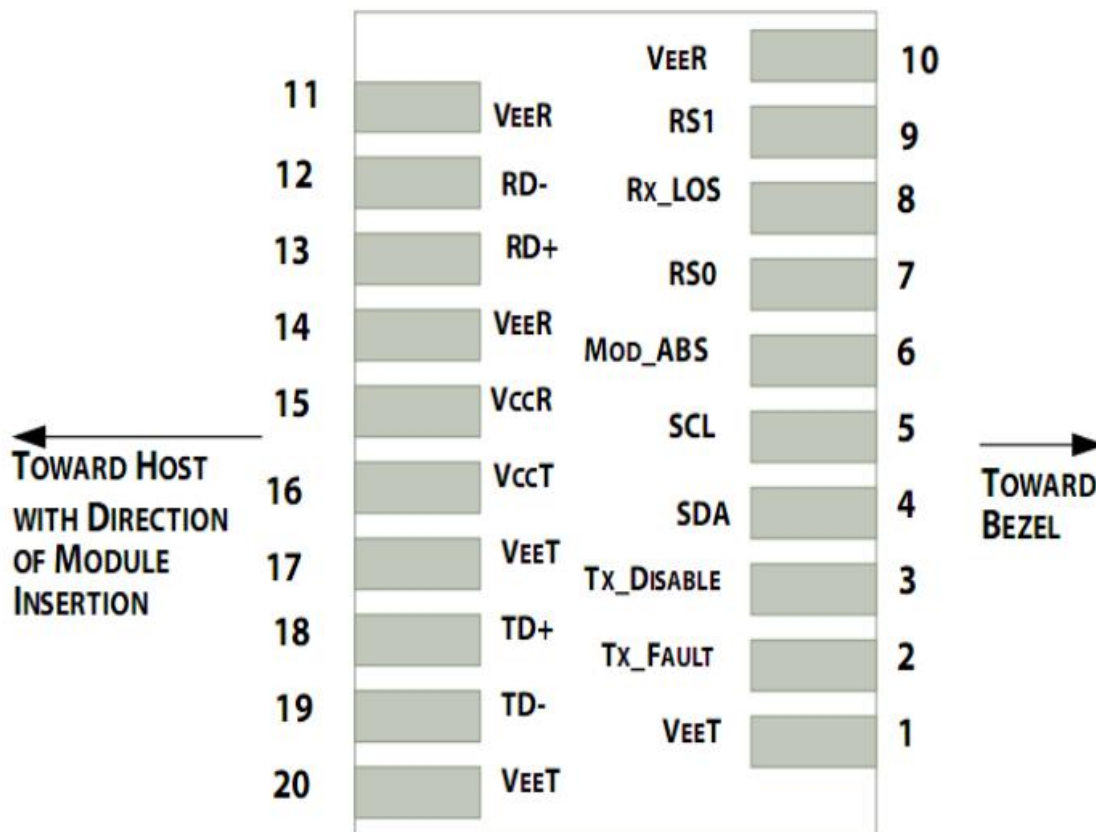

Pin-out of Connector Block on Host Board

## Absolute Maximum Ratings

Parameter	Symbol	Min.	Typ.	Max.	Unit	Note
Storage Temperature	Ts	-40		+85	°C	
Relative Humidity	RH	0		95	%	
Power Supply Voltage	VCC	-0.5		+4	V	

## Recommended Operating Conditions

Parameter	Symbol	Min.	Typ.	Max.	Unit	Note
Case Operating Temperature	Tc	0		70	°C	Commercial
	Tl	-40		85	°C	Industrial
Power Supply Voltage	Vcc	3.13	3.3	3.47	V	
Power Supply Current	Icc			310	mA	
Data Rate	BR		10.31		Gbps	
9/125um G.652 SMF	Lmax			20	km	

## Electrical Characteristics

Parameter	Symbol	Min.	Typ.	Max.	Unit	Note
<b>Transmitter</b>						
Tx Disable Input-High	VDISH	2		Vcc+0.3	V	
Tx Disable Input-Low	VDISL	0		0.8	V	
Tx Fault Input-High	VTxFH	2		Vcc+0.3	V	
Tx Fault Input-Low	VTxFL	0		0.8	V	
<b>Receiver</b>						
LOSS -High	V <sub>LOSH</sub>	2		Vcc+0.3	V	
LOSS -Low	V <sub>LOSL</sub>	0		0.8	V	

## Optical Characteristics

Parameter	Symbol	Min.	Typ.	Max.	Unit	Note
<b>Transmitter</b>						
Average Output Power	POUT	-4		2	dBm	
Transmitter OFF Output Power	Poff			-45	dBm	
Center Wavelength	$\lambda_C$	1260	1270	1280	nm	DFB Laser
Side mode suppression ratio	SMSR			30	dB	
Spectrum Bandwidth(-20dB)	$\sigma$			1	nm	
Extinction Ratio	ER	3.5			dB	
<b>Receiver</b>						
Receiver Sensitivity	SENS			-14.4	dBm	1
Receiver Overload		0.5			dBm	
Input Optical Wavelength	$\lambda_C$	1320	1330	1340	nm	PIN-TIA
LOS De-assert	LOSD			-17	dBm	
LOS Assert	LOSA	-30			dBm	2
LOS Hysteresis		0.5		5	dB	

**Note:**

1. Measured with PRBS=2<sup>31</sup>-1 at BER = 10<sup>-12</sup>@10.3125Gbps
2. When LOS de-asserted, the RX data+/- output is High-level (fixed).

## EEPROM Information

EEPROM memory map specific data field description is as below:

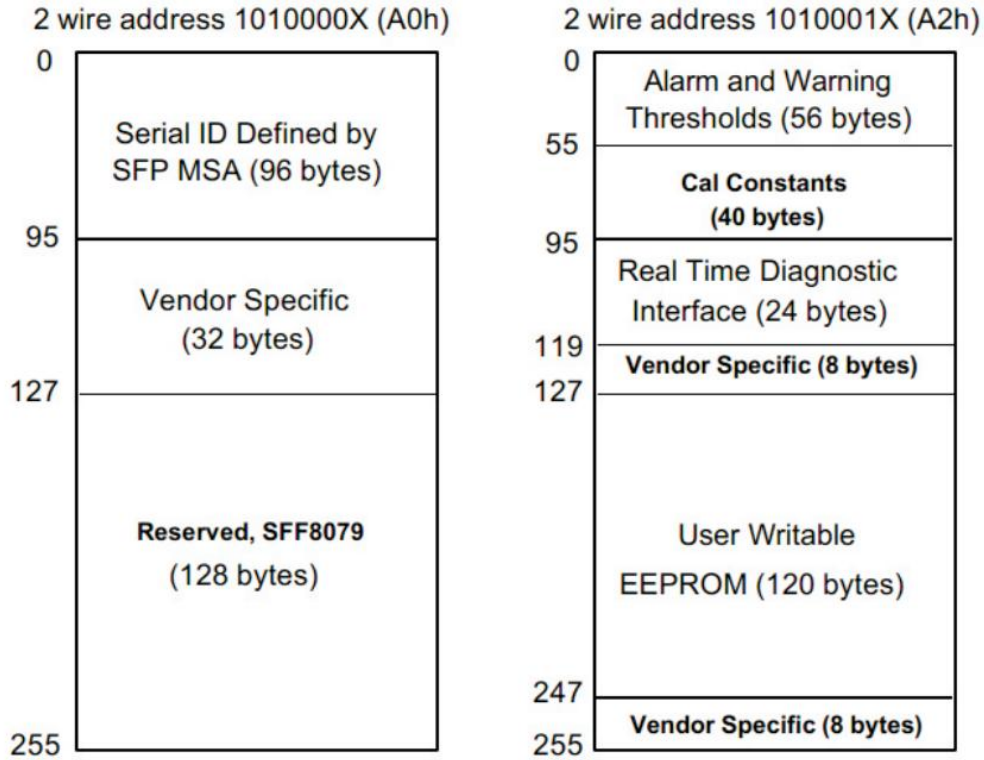

## Digital Diagnostic Monitoring Interface

Five transceiver parameter values are monitored. The following table defines the monitored parameter's accuracy.

Parameter	Range	Accuracy	Calibration
Temperature	0 to +70°C (C)	±3°C	Internal
	-40 to +85°C (I)		
Voltage	2.97 to 3.63V	±3%	Internal
Bias Current	0 to 100mA	±10%	Internal
TX Power	-4 to 2 dBm	±3dBm	Internal
RX Power	-14.4 to 0 dBm	±3dBm	Internal



## Recommend Circuit Schematic

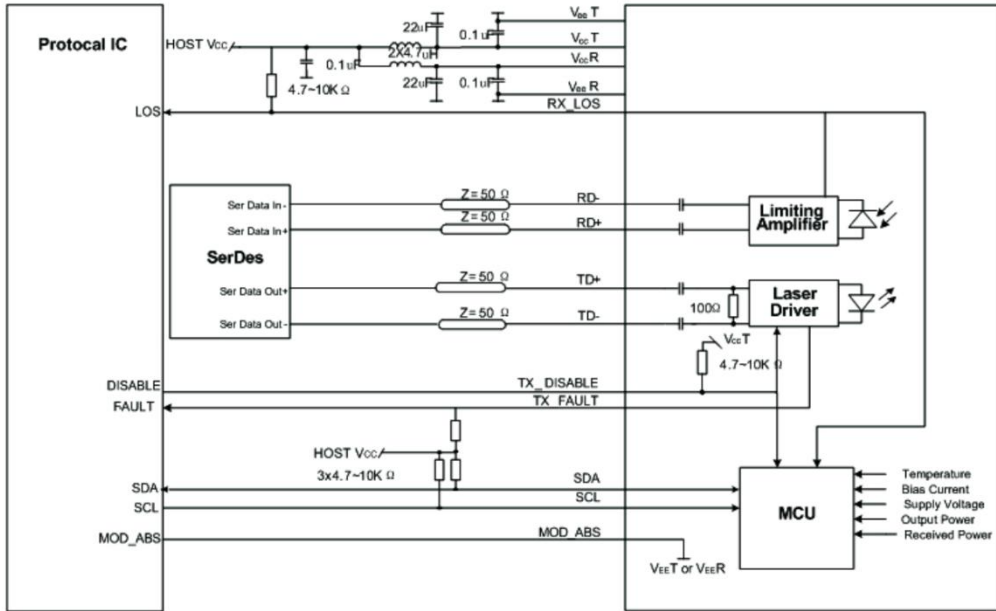

## Mechanical Specifications

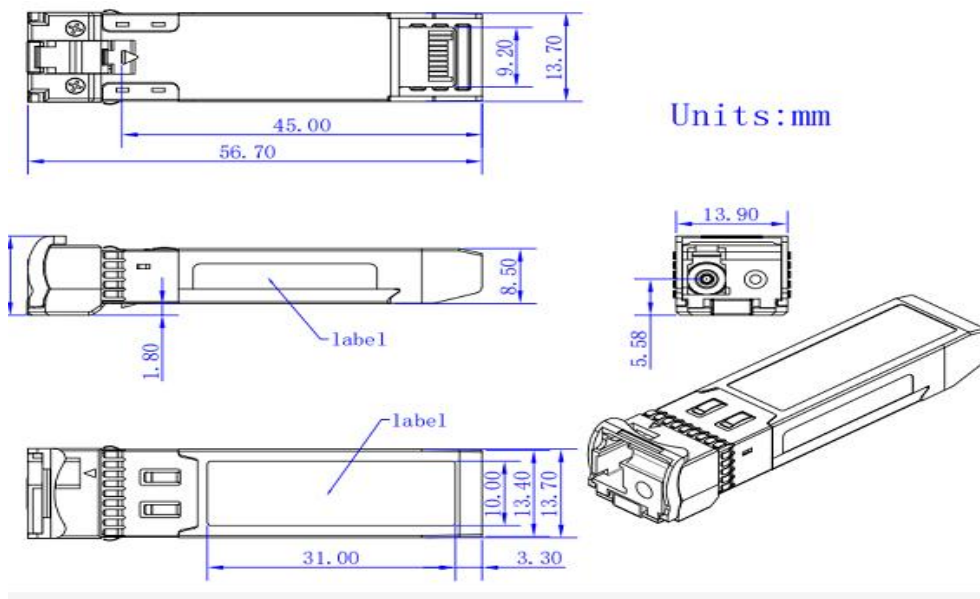



## Revision History

Revision	Initiated	Reviewed	Approved	DCN	Release Date
Version1.0	Zhangchengxing	pengyanhui	Liubin	New Released.	July 28, 2017
Version1.1	Zhangchengxing	pengyanhui	Liubin	Updated document structure	Dec 10,2020

## ◆ UNSFP10-3327SL10X

10Gbps SFP+ Tx1330nm/Rx1270nm BiDi 10Km Transceiver

### Product Feature

- Up to 11.3G/s data links
- DFB laser transmitter and PIN photo-detector
- Up to 10km on 9/125 $\mu$ m SMF
- Hot-pluggable SFP footprint
- Single LC/UPC type pluggable optical interface
- Low power dissipation
- Metal enclosure, for lower EMI
- RoHS compliant and lead-free
- Single +3.3V power supply
- Support Digital Diagnostic Monitoring interface
- Compliant with SFF-8472
- Case operating temperature

Commercial: 0°C to +70°C

Industrial: -40°C to +85°C





Shenzhen UnitekFiber Solution Limited

## Applications

- 10GBASE-BX&10GBASE-BX/LW
- 10GSONET/SDH,OTU2/2e
- Other Optical Links

## Product Description

KSFP10-3327SL20X Small Form Factor Pluggable (SFP) transceivers are compatible with the Small Form Factor Pluggable Multi-Sourcing Agreement (MSA). The transceiver consists of five sections: the LD driver, the limiting amplifier, the digital diagnostic monitor, the DFB laser and the PIN photo-detector. The module data link up to 10KM in 9/125um single mode fiber.

The optical output can be disabled by a TTL logic high-level input of Tx Disable, and the system also can disable the module via I2C. Tx Fault is provided to indicate that degradation of the laser. Loss of signal (LOS) output is provided to indicate the loss of an input optical signal of receiver or the link status with partner. The system can also get the LOS (or Link)/Disable/Fault information via I2C register access.

## Product Selection

Part Number	Operating Case temperature	DDMI
KSFP10-3327SL20C	Commercial(0~70°C)	Yes
KSFP10-3327SL20I	Industrial(-40~85°C)	Yes

## Pin Descriptions

Pin	Symbol	Name/Description	NOTE
1	VEET	Transmitter Ground (Common with Receiver Ground)	1
2	TFAULT	Transmitter Fault.	
3	TDIS	Transmitter Disable. Laser output disabled on high or open.	2
4	SDA	2 wire ID interface, SDA	3
5	SCL	2 wire ID interface, SCL	3
6	MOD_DEF(0)	Module Definition 0. Grounded within the module.	3
7	RS0	No connection required	4
8	LOS	Loss of Signal indication. Logic 0 indicates normal operation.	5
9	RS1	Receiver Ground (Common with Transmitter Ground)	1
10	VEER	Receiver Ground (Common with Transmitter Ground)	1
11	VEER	Receiver Ground (Common with Transmitter Ground)	1
12	RD-	Receiver Inverted DATA out. AC Coupled	
13	RD+	Receiver Non-inverted DATA out. AC Coupled	
14	VEER	Receiver Ground (Common with Transmitter Ground)	1
15	VCCR	Receiver Power Supply	
16	VCCT	Transmitter Power Supply	
17	VEET	Transmitter Ground (Common with Receiver Ground)	1
18	TD+	Transmitter Non-Inverted DATA in. AC Coupled.	
19	TD-	Transmitter Inverted DATA in. AC Coupled.	
20	VEET	Transmitter Ground (Common with Receiver Ground)	1

Notes:

1. Circuit ground is internally isolated from chassis ground.
2. Laser output disabled on  $T_{DIS} > 2.0V$  or open, enabled on  $T_{DIS} < 0.8V$ .
3. Should be pulled up with 4.7k - 10kohms on host board to a voltage between 2.0V and 3.6V. MOD\_DEF (0) pulls line low to indicate module is plugged in.
4. This is an optional input used to control the receiver bandwidth for compatibility with multiple data rates (most likely Fiber Channel 1x and 2x Rates). If implemented, the input will be internally pulled down with  $> 30k\Omega$  resistor. The input states are:
  - Low (0 – 0.8V): Reduced Bandwidth
  - ( $>0.8, < 2.0V$ ): Undefined
  - High (2.0 – 3.465V): Full Bandwidth
  - Open: Reduced Bandwidth
5. LOS is open collector output should be pulled up with 4.7k - 10kohms on host board to a voltage between 2.0V and 3.6V. Logic 0 indicates normal operation; logic 1 indicates loss of signal.

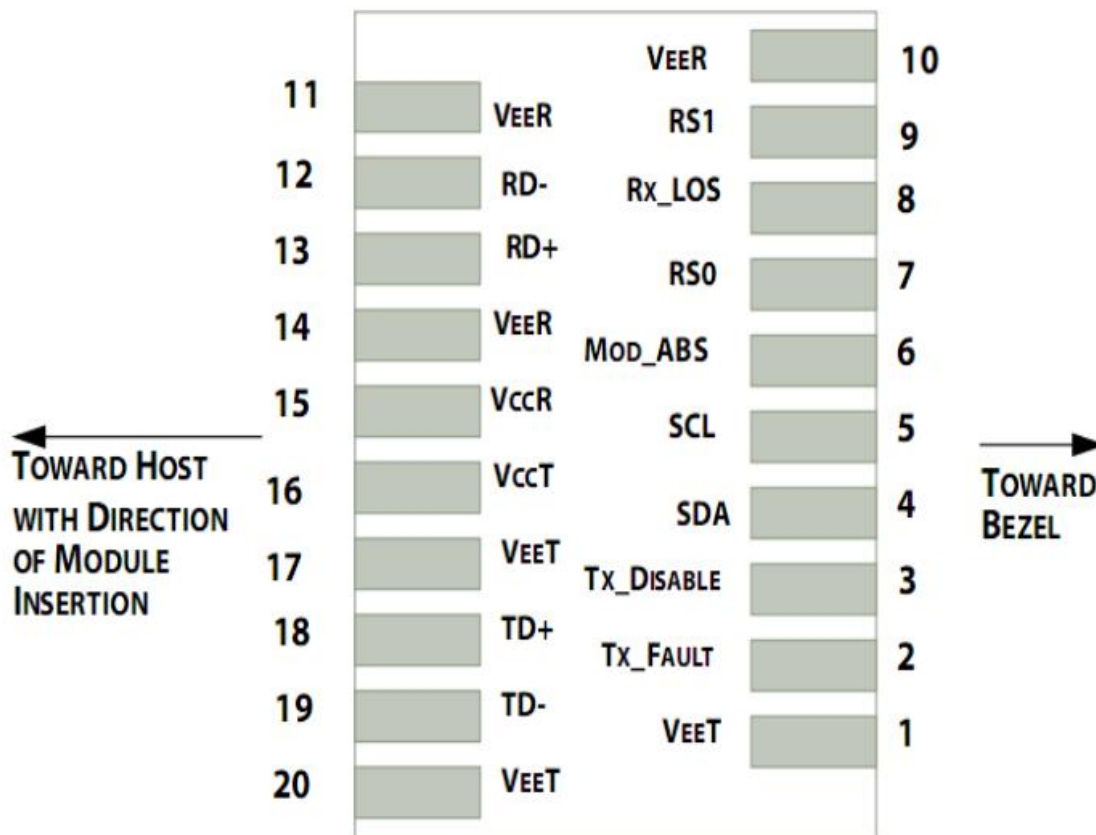

Pin-out of Connector Block on Host Board

## Absolute Maximum Ratings

Parameter	Symbol	Min.	Typ.	Max.	Unit	Note
Storage Temperature	Ts	-50		+95	°C	
Relative Humidity	RH	0		95	%	
Power Supply Voltage	VCC	-0.5		+4	V	

## Recommended Operating Conditions

Parameter	Symbol	Min.	Typ.	Max.	Unit	Note
Case Operating Temperature	Tc	0		70	°C	Commercial
	Tl	-40		85	°C	Industrial
Power Supply Voltage	Vcc	3.13	3.3	3.47	V	
Power Supply Current	Icc			300	mA	
Data Rate	BR		10.31		Gbps	
9/125um G.652 SMF	Lmax			20	km	

## Electrical Characteristics

Parameter	Symbol	Min.	Typ.	Max.	Unit	Note
<b>Transmitter</b>						
Tx Disable Input-High	VDISH	2		Vcc+0.3	V	
Tx Disable Input-Low	VDISL	0		0.8	V	
Tx Fault Input-High	VTxFH	2		Vcc+0.3	V	
Tx Fault Input-Low	VTxFL	0		0.8	V	
<b>Receiver</b>						
LOSS -High	V <sub>LOSH</sub>	2		Vcc+0.3	V	
LOSS -Low	V <sub>LOSL</sub>	0		0.8	V	



## Optical Characteristics

Parameter	Symbol	Min.	Typ.	Max.	Unit	Note
<b>Transmitter</b>						
Average Output Power	POUT	-4		2	dBm	
Transmitter OFF Output Power	Poff			-45	dBm	
Center Wavelength	$\lambda_C$	1320	1330	1340	nm	DFB Laser
Side mode suppression ratio	SMSR			30	dB	
Spectrum Bandwidth(-20dB)	$\sigma$			1	nm	
Extinction Ratio	ER	3.5			dB	
<b>Receiver</b>						
Receiver Sensitivity	SENS			-14.4	dBm	1
Receiver Overload		0.5			dBm	
Input Optical Wavelength	$\lambda_C$	1260	1270	1280	nm	PIN-TIA
LOS De-assert	LOSD			-17	dBm	
LOS Assert	LOSA	-30			dBm	2
LOS Hysteresis		0.5		5	dB	

**Note:**

1. Measured with PRBS=2<sup>31</sup>-1 at BER = 10<sup>-12</sup>@10.3125Gbps
2. When LOS de-asserted, the RX data+/- output is High-level (fixed).

## EEPROM Information

EEPROM memory map specific data field description is as below:

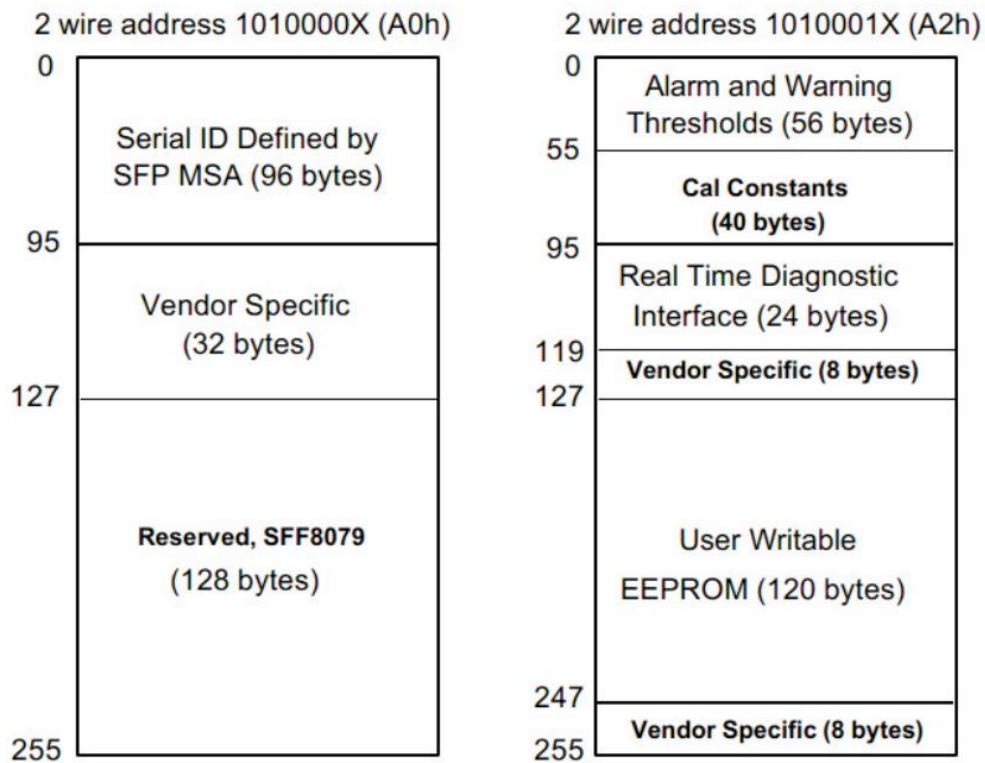

## Digital Diagnostic Monitoring Interface

Five transceiver parameter values are monitored. The following table defines the monitored parameter's accuracy.

Parameter	Range	Accuracy	Calibration
Temperature	0 to +70°C (C)	±3°C	Internal
	-40 to +85°C (I)		
Voltage	2.97 to 3.63V	±3%	Internal
Bias Current	0 to 100mA	±10%	Internal
TX Power	-4 to 2 dBm	±3dBm	Internal
RX Power	-14.4 to 0 dBm	±3dBm	Internal

## Recommend Circuit Schematic

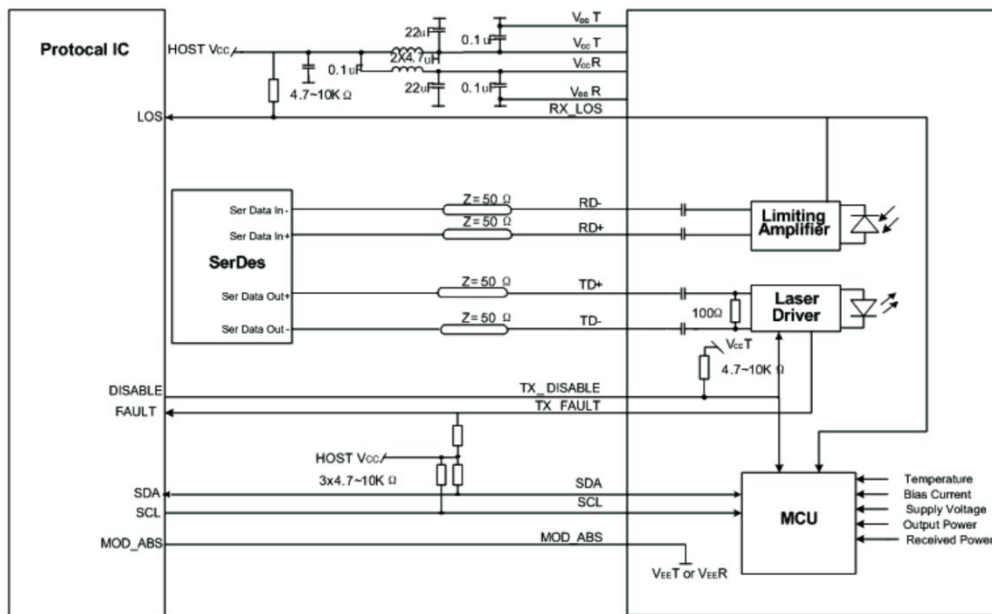

## Mechanical Specifications

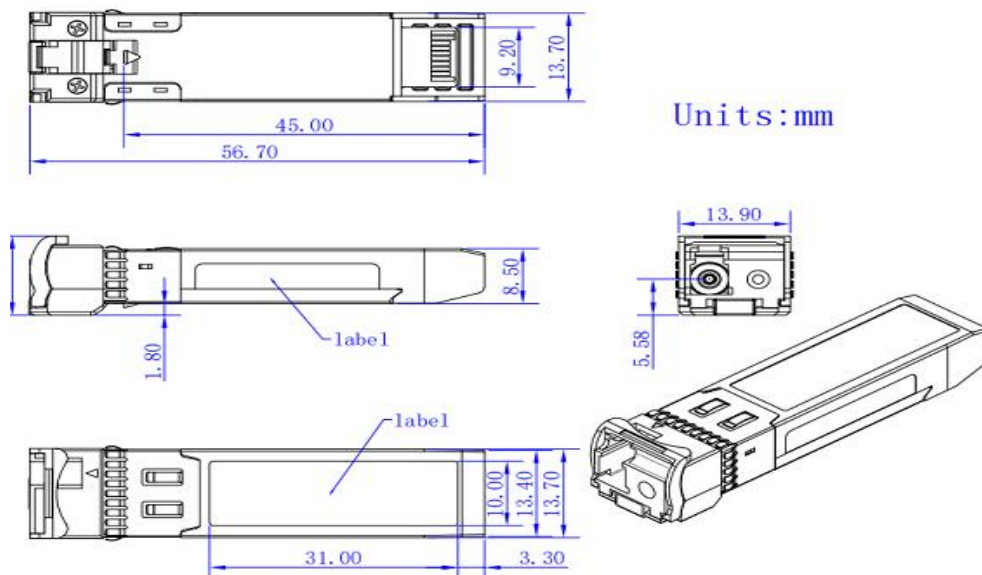

## Revision History

Revision	Initiated	Reviewed	Approved	DCN	Release Date
Version1.0	Zhangchengxing	pengyanhui	Liubin	New Released.	July 28, 2017
Version1.1	Zhangchengxing	pengyanhui	Liubin	Updated document structure	Dec 10,2020